

User Manual

PB-350 SERIES BALANCES



Table of Contents

1	INTENDED USE	1
2	PRECAUTIONS	1
2.1	Accumulator / BatteryPack	2
2.2	Operation in a Strong ElectrostaticField	2
2.3	Maintenance Activities	2
3	WARRANTY CONDITIONS	3
4	UNPACKING ANDASSEMBLY	3
5	GETTING STARTED	4
6	BALANCELEVELING	5
7	KEYPAD	5
8	KEYS' FUNCTIONS	6
9	INSCRIPTIONS ON THE DISPLAY	6
10	USER MENU	7
10.1	Submenus	7
10.2	Browsing User Menu	8
10.3	Keypad	8
10.4	Return to the Weighing Mode	9
11	WEIGHING	9
11.1	Taring	10
11.2	Inscribing Tare Value	10
11.3	Zeroing	11
11.4	Selection of Start Weighing Unit	11
11.5	Temporarily Selected Unit	12
12	SCALE CALIBRATION	12
12.1	External Calibration	12
12.2	User Calibration	13
12.3	Manual Internal Calibration	13
12.4	Automatic Internal Calibration	13
12.5	Automatic Internal Calibration Time	14
12.6	Calibration Test	14
12.7	Calibration Report	15
13	MAIN SCALE PARAMETERS	15
13.1	Filter	15
13.2	Value Release	15
13.3	Ambient Conditions	15
13.4	Autozero Function	16
13.5	Tare Function	16
13.6	Tare: Enter Mode	16
13.7	Tare: Values Memory	17
13.7.1	Entering Tare Value to the Weighing Device Memory	17
13.7.2	Selecting Tare Value from the Weighing Device Memory	17
13.8	Last Digit	18
14	COMMUNICATION	18
14.1	RS232 (1) Port	18
14.2	RS232 (2) Port	18
14.3	USB A Port	18
14.4	USB B Port	19
15	PERIPHERAL DEVICES	19
15.1	Computer	19
15.1.1	Computer Port	19
15.1.2	Continuous Transmission	19
15.1.3	Printout Interval for Continuous Transmission	19
15.2	Printer	20
15.2.1	Printer Port	20
15.3	Additional Display	20
15.3.1	Additional Display Port	20
16	PRINTOUTS	20
16.1	Calibration Report	20
16.2	GLP Printout	21
16.3	Variables List	21
17	OTHER PARAMETERS	22
17.1	Backlight	22
17.2	'Beep' Sound	22
17.3	Automatic Shutdown	22
17.4	Date and Time	23
17.5	Default User Settings	23
18	SCALE DATA	23
19	WORKING MODES	23
19.1	Running Working Mode	24
19.2	Working Modes Local Settings	24
19.2.1	Working Mode Accessibility	24
19.2.2	Save Mode	25
19.2.3	Automatic Printout Time Interval	25
19.2.4	Lo Threshold	25
20	WORKING MODE – WEIGHING	26
20.1	Local Settings	26











21	WORKING MODE – PARTS COUNTING	26
21.1	Local Settings	26
21.1.1.	Selecting Working Mode	26
21.2.	Setting Sample Mass by Entering Mass of a Single Part	26
21.3.	Setting Sample Mass by Determining Mass of a Single Part	27
22	WORKING MODE – +/- CONTROL	28
22.1	Local Settings	28
22.2	Declaring Checkweighing Thresholds	28
23	WORKING MODE – PERCENT WEIGHING	28
23.1	Local Settings	28
23.1.1.	Selecting Working Mode	29
23.2.	Reference Sample Mass Determined by Weighing	29
23.3.	Reference Sample Mass Determined by Entering the Mass Value	29
24	WORKING MODE – PEAK HOLD	29
24.1	Local Settings	29
24.2	Peak Hold Operation.....	30
25	WORKING MODE – TOTALIZING	30
25.1	Local Settings	30
25.2	Totalizing Operation	30
25.3	Report Example	31
26	WORKING MODE – ANIMAL WEIGHING	31
26.1	Local Settings	31
26.2	Animal Weighing Operation	31
27	IMPORT/EXPORT	32
27.1	Weighing Records Export	32
27.2	ALIBI Weighings Export	32
27.3	Parameters Export / Import	32
28	DIAGRAMS OF CONNECTION CABLES	33
29	ERROR COMMANDS	34
30	UNDER-PAN WEIGHING	34
31	MAIN DIMENSIONS	36
32	TROUBLE SHOOTING	38

1 INTENDED USE

Cole-Parmer® PB-350 Series precision scales enable fast and accurate mass measurements under laboratory and industrial conditions. The devices are equipped with an internal battery which allows their operation in places where there is no access to the mains. The PB-350 Series features a stainless-steel weighing pan, and a backlit LCD guaranteeing clear weighing result presentation.

2 PRECAUTIONS

Prior to installation, use or maintenance activities, carefully read this user manual and follow the provided guidelines.

	Prior to the first use, carefully read this user manual. Use the weighing device only as intended.
	Place weighed loads in the center of the weighing pan.
	Load the weighing pan with loads of gross weight which does not exceed the maximum capacity.
	Do not leave heavy loads on the weighing pan for longer periods of time.
	Protect the indicator against considerable temperature variation, solar and UV radiation, substances causing chemical reactions.
	The PB-350 scale must not be operated in hazardous areas endangered with explosion of gases, and in dusty environments.
	In case of damage, immediately unplug the device from the mains.
	Scales to be decommissioned must be decommissioned in accordance with valid legal regulations.
	Do not let battery discharge in case of prolonged storage of the device in low temperature.
	Accumulators do not belong to regular household waste. The European legislation requires discharged accumulators to be collected and disposed separately from other communal waste with the aim of being recycled. Symbols on batteries identify harmful compounds: Pb = lead, Cd = cadmium, Hg = mercury. Dear user, you are obliged to dispose of the worn out batteries as regulated.
	If the scale is to be operated in conditions that are difficult due to electrostatics (e.g. printing house, packing center, etc.), you must connect it to the earth wire. To enable this, the device features functional earthing terminal, marked with \perp symbol.

2.1 Accumulator / Battery Pack

The device connected to mains power monitors the battery state and charges it if possible. After sudden lack of power supply from the mains the device automatically switches to accumulator without breaking operation.

Cole-Parmer PB-350 scales (20kg and below capacity) are devices designed to be supplied from **SLA** accumulators (*Sealed lead acid type*) **6V** and capacity **3** to **4Ah** charged while connected to mains without stopping operation.

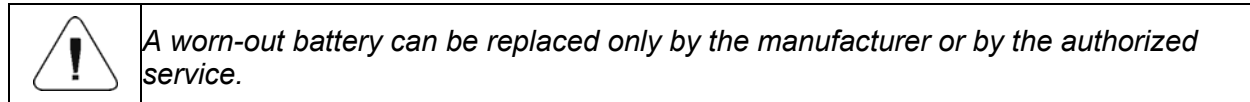

Caution:

Some symbols on accumulators identify harmful elements/compounds: Pb = lead, Cd = cadmium, Hg = mercury.

2.2 Operation in a Strong Electrostatic Field

Connect it to the clamp terminal signed \perp .

2.3 Maintenance Activities

It is necessary to uninstall the weighing pan and other detachable components prior to cleaning the balance, this guarantees safety.

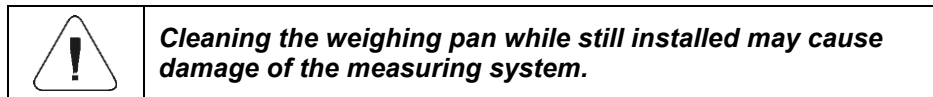

Cleaning ABS components

To clean dry surfaces and avoid smudging, use clean non-coloring cloths made of cellulose or cotton. You can use a solution of water and detergent (soap, dishwashing detergent, glass cleaner). Gently rub the cleaned surface and let it dry. Repeat cleaning process if needed.

Cleaning stainless steel components

Avoid using cleansers containing any corrosive chemicals, e.g. bleach (containing chlorine). Do not use abrasive substances. Always remove the dirt using microfiber cloth to avoid damage of protective coating.

In case of a daily maintenance:

2. For best results, add a little dishwashing detergent.

Cleaning powder-coated components

For the preliminary cleaning stage, you need a wet sponge featuring large holes, this will help you to remove loose, heavy dirt.

Do not use cleansers containing abrasive substances.

Next using cloth and cleanser-water solution (soap, dishwashing liquid) gently rub the cleaned surface.

Avoid using cleanser without water since it may result in damage of the cleaned surface, please note that large amount of water mixed with cleanser is a must.

3 WARRANTY CONDITIONS

- A. Cole-Parmer is obliged to repair or change those elements that appear to be faulty because of production and construction reason,
- B. Defining defects of unclear origin and outlining methods of elimination, can be settled only in participation of a user and the manufacturer representatives,
- C. Cole-Parmer does not take any responsibility connected with destructions or losses derives from non-authorized or inappropriate (not adequate to manuals) production or service procedures,
- D. Warranty does not cover:
 - Mechanical failures caused by inappropriate maintenance of the device or failures of thermal or chemical origin or caused by atmospheric discharge, over voltage in mains, or other random event,
 - Inappropriate cleaning.
- E. Loss of warranty appears after:
 - Access by an unauthorized service
 - Intrusion into mechanical or electronic construction of, unauthorized people
 - Removing or destroying protection stickers.

4 UNPACKING AND ASSEMBLY

Models: PB-350-1000(i), PB-350-2000(i), PB-350-6000(i), PB-350-10000, PB-350-20000

- Unpack and put the scale on a flat even stable surface far away from sources of heat,
- Install the weight pan according to the drawing below:

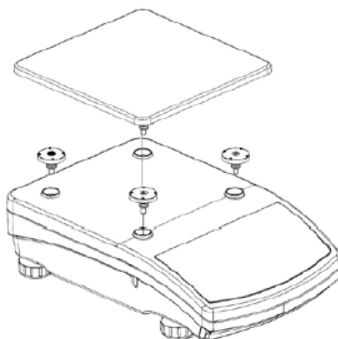

5 GETTING STARTED

- After unpacking and mounting the scale, level the scale. Adjust the leveling feet until the leveling bubble reaches the correct location.

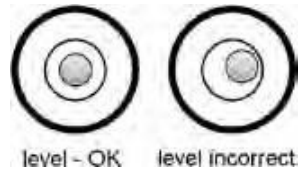

Turn the device on using the  key – keep pressing the key for about 0.5 sec

- Wait for the test completion

 - stable result

kg - weight unit

6 BALANCE LEVELING

- Operation temperature range for this device is outlined as +15°C to +30°C;
- After powering up this device requires 30 minute warming up
- During the warm-up time the indication can change
- User calibration should be performed after the warm-up time.
- Temperature and humidity changes during operation can increase measurement errors, which can be minimized by performing the user calibration process.

7 KEYPAD



PB-350-1000, PB-350-2000, PB-350-6000, PB-350-10000, PB-350-20000



PB-350-2000i, PB-350-6000i

8 KEYS' FUNCTIONS



Switching on/off

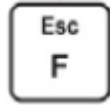

Function key (working mode selection)



Enter key/sending a weighing result to printer or computer



Zeroing





Taring

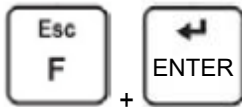

Manual internal calibration (.HC models only)

Notice:



After pressing  +  keys' functions changes. The way of operation in this mode is described in details further in this manual.

9 INSCRIPTIONS ON THE DISPLAY

No	Text string	Description
1	FIL	Filter level
2	bAud	Transmission baud rate
3	PCS	Piece counting
4	HiLo	+/- control according to a standard mass
5	rEPL	Automatic printout
6	StAb	The condition of printing data
7	Auto	Autozero correction
8	t1	Power save – time to switch off while no operation
9	toP	Latch of the max measurement
10	Add	Totalizing
11	AnLS	Weighing animals

12	tArE	Memory of 9 tare values
13		Indication in autozero zone (indication = exact zero)
14		Stable result (ready to read)
15	PCS	Operation mode - counting pieces
16	kg (g)	Operation mode - weighing
17		Rechargeable battery pack or battery discharged (BAT-LO)
18	Net	Tare function has been used
19	Min	+/- control with reference to the standard mass: setting the lower threshold or mass below the first threshold
20	OK	+/- control with reference to the standard mass: load mass between the thresholds
21	Max	+/- control with reference to the standard mass: setting the upper threshold or mass over the second threshold

10 USER MENU

10.1 Submenus

User's menu is divided into **9** basic submenus. Each group has its own characteristic name preceded by the letter **P** and a number.









P1.CAL		
	1.1.CA-E	External Calibration
	1.2.CA-u	User Defined Calibration
	1.4.AtS	Automatic Internal Calibration ("i" models only)
	1.5.ACL	Automatic Internal Calibration conditions ("i" models only)
	1.6.CAC	Automatic Calibration Time Setting
P2.rEAD		
	2.1.FiL	Filter Level
	2.2.APPr	Value Release
	2.3.Enut	Ambient Conditions
	2.4.Aut	Autozero Function
	2.5.tArA	Tare Function
	2.6.ttr	Tare: Enter mode
	2.7.tArn	Tare: Values Memory
	2.8.LdiG	Last Digit
P3.Func		
	3.1.UUGG	Weighing
	3.2.PcS	Parts Counting
	3.3.HiLo	+/- Control
	3.4.dEu	% Weighing
	3.5.toP	Peak Hold
	3.6.Add	Totalizing
	3.7.AnLs	Animal Weighing
P4.Conn		



	4.1.rS1	RS232 (1) Port
	4.2.rS2	RS232 (2) Port
P5.duce		
	5.1.PC	Computer
	5.2.Prtr	Printer
	5.3.AdSP	Additional Display
P6.Prnt		
	6.1.CrEP	Calibration Report
	6.2.GLP	GLP Printout
P7.Othr		
	7.1.bLbt	Backlight
	7.2.bEEP	'Beep' Sound
	7.3.t1	Automatic Shutdown
	7.4.SdAt	Current Date
	7.5.Stnn	Current Time
	7.6.FdAt	Date Format
	7.7.Ftin	Time Format
	7.8.dFLu	Default User Settings
P8.InFo		
	8.1.Fab	Serial Number
	8.2.PurS	Program Version
	8.4.PstP	Settings Printout
P9.Unit		
	9.1.UnSt	Start unit
	9.2.Unin	Temporary Unit

10.2 Browsing User Menu

Use scale's keys to move inside the menu.

10.3 Keypad

 + 	Press to enter the main menu.
 + 	Press to: <ul style="list-style-type: none"> • enter tare manually. • enter tare from tare database, • change value by 1 digit up, • scroll the menu up.
 + 	Press to check battery/accumulator state.
 + 	Press to view date/time.
	Press to: <ul style="list-style-type: none"> • scroll the menu down, • change current parameter value.

	Press to: <ul style="list-style-type: none"> • enter given submenu, • modify given parameter.
	Press to confirm modification.
	Press to: <ul style="list-style-type: none"> • exit, function remains unmodified, • move one menu level up.

10.4 Return to the Weighing Mode



The changes that have been introduced should be saved in order to keep them in the memory for good.



While leaving parameters press  key until the text **<SAuE?>** appears on the display. Then press:



– to save changes or



– to leave without changes.

11 WEIGHING

Place a load you want to weigh on the weighing pan. When the  pictogram appears, it means that the result is stable and ready to read. In order to assure long-term operation and appropriate measurements of weighted loads, the following precautions should be taken into consideration:

- Loads should be placed on the pan delicately and carefully in order to avoid mechanical shocks:

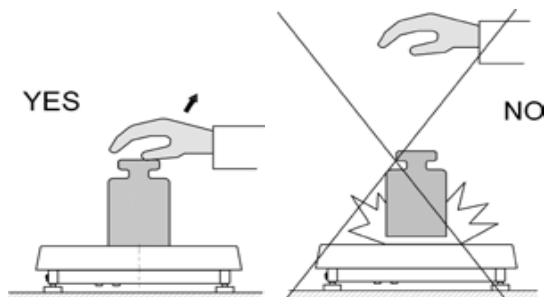

- Loads should be placed centrally on the pan (errors caused

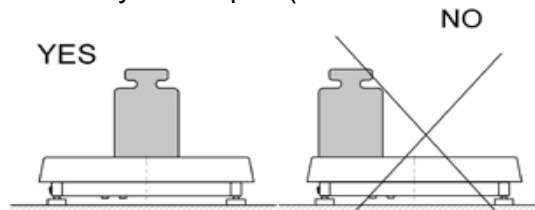

by eccentric weighing are outlined by standard PN-EN 45501 ch. 3.5 and 3.6.2):

- Do not load the pan with concentrated force:

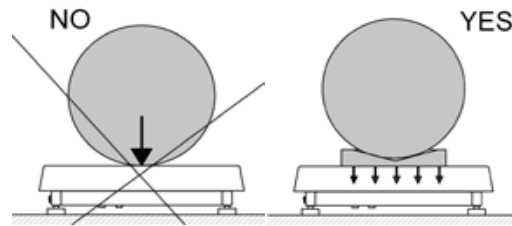

- Avoid side loads, particularly side shocks should be avoided

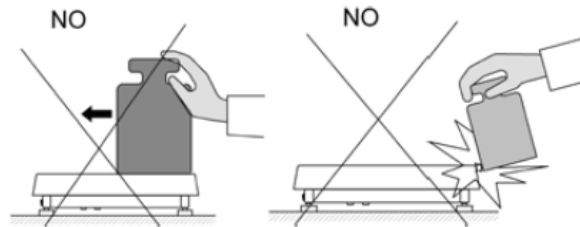

11.1 Taring

In order to determine the net mass put the packaging on the pan. After stabilizing press -



(**Net** pictogram will be displayed in the left upper corner and zero will be indicated).

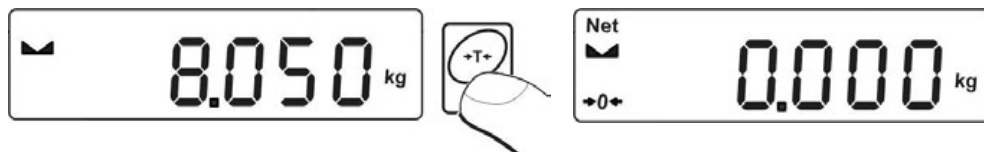

After placing a load on the weight pan net mass will be shown.

Taring is possible within the whole range of the scale. After unloading the pan the display shows the tarred value with minus sign.





Notice:



*Taring cannot be performed when a negative or zero value is being displayed. In such case **-Err3-** appears on the display and short audible signal will be emitted.*

11.2 Inscribing Tare Value

You can also inscribe a tare value. While in weighing's mode press:

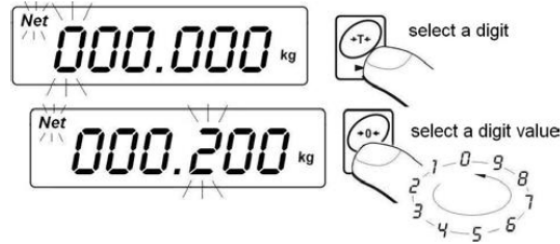

- Press simultaneously  and ,
- You will see :



- Using  and  set the tare value,
- Press , to confirm value
- Program returns to weighing's mode. The inscribed tare value can be seen on the display with "-" sign,
- Tare can be inscribed anytime in weighing's mode.

11.3 Zeroing

To **ZERO** the scale press: .

The scale will display zero and following pictograms:  and . Zeroing is only possible within the scope of $\pm 2\%$ of full scale. While zeroing outside the scope of $\pm 2\%$ you will see **<Err2>**. Zeroing is possible only in stable state.



Notice:

*Zeroing is possible only within the $\pm 2\%$ interval of the maximal range. If zeroing is performed beyond this range the **-Err2-** message and short audible signal will be emitted.*

11.4 Selection of Start Weighing Unit

Parameter for setting unit that is displayed and used after device start-up.



Procedure:

- Enter **<P9.Unit / 9.1.UnSt>** submenu.
- Press  key, available units are displayed successively one by one.
 - g (gram)
 - kg (kilogram)
 - ct (carat)
 - lb (pound)
- Select start unit and press  key, next go back to the home screen, to do it press  key.
- Upon next start-up the scale runs with set startunit.

11.5 Temporarily Selected Unit

Temporary unit runs from the moment it is set to the scale shut-down and restart.

Procedure:

- Enter **<P9.Unit / 9.2.Unin>** submenu.
- Press  key, available units are displayed successively one by one.
 - g (gram)
 - kg (kilogram)
 - ct (carat)
 - lb (pound)
- Select temporary unit and press  key, next go back to the home screen.

12 SCALE CALIBRATION

In precise scales changes of gravitational acceleration have noticeable influence. The gravitational acceleration changes with altitude and latitude. Every scale must be calibrated to the place of use especially when the place changes. Frequent calibration also prevents weighing process from the influence of humidity and temperature.

For assuring the maximal accuracy of weighing a periodical user calibration is required.

Calibration should be performed:

- Before weighing process
- After a long break between series of measurements
- After the ambient temperature change
- If the scale has been relocated



Caution:

*It should be remembered that the calibration process should be performed with the empty pan! The calibration process can be terminated by pressing **Esc** when necessary.*

12.1 External Calibration

External calibration should be carried out using an external adjustment weight of class F₁ or F₂



Procedure:

- Enter **<P1.CAL / 1.1.CA-E>** submenu, text **<UnLoAd>** (remove weight) is displayed.
- Remove any load from the weighing pan and press  key.
- Mass of an empty weighing pan is determined, this is signaled with display of 'dash', **< - >**. Next, the text **<LoAd>** (load weight) and mass value that is to be loaded, e.g. **2000 g** (varies by scale model), are displayed.
- Load the weighing pan with weight of specified mass value and press  key.
- Weight mass is determined, this is signaled with display of 'dash', **< - >**. Next, text **<UnLoAd>** (remove weight) is displayed.
- Remove the load from the weighing pan, **<1.1.CA-E>** submenu is displayed.

12.2 User Calibration

User calibration must be carried out using an external weight of class F₁, and of mass value ≥ 30% of the maximum capacity value.

Procedure:

- Enter **<P1.CAL / 1.2.CA-u>** submenu, edit box for declaring weight mass is displayed (the mass value must be ≥ 30% of the maximum capacity value).
- Enter weight mass value and press  key to confirm, text **<UnLoAd>** (remove weight) is displayed.
- Remove the load from the weighing pan and press  key.
- Mass of an empty weighing pan is determined, this is signaled with display of 'dash', **< - >**. Next, text **<LoAd>** (load weight) and mass value that is to be loaded, e.g. **2000g**, are displayed.
- Load the weighing pan with weight of specified mass value and press  key.
- Weight mass is determined, this is signaled with display of 'dash', **< - >**. Next, text **<UnLoAd>** (remove weight) is displayed.
- Remove the load from the weighing pan, **<1.2.CA-u>** submenu is displayed.

12.3 Manual Internal Calibration

Manual internal calibration is carried out using a built-in calibration weight. Only available on models: PB-350-1000i, PB-350-2000i and PB-350-6000i

Procedure:

In the course of operation press  key, calibration process is run automatically

- Process begins, when in progress it is signaled with display of 'dash' **< - >**.
- Upon completion, the scale automatically returns to the weighing mode.

12.4 Automatic Internal Calibration

Only available on models: PB-350-1000i, PB-350-2000i and PB-350-6000i

Automatic internal calibration is triggered:

- After connection of the scale to the mains
- When temperature variation occurs
- After passage of specified time interval

In case of an automatic internal calibration it is necessary to declare condition that is to trigger the automatic calibration. To declare condition go to **<1.5.ACL>** parameter.

nonE	Calibration disabled
tnnP	Calibration triggered by temperature variation greater than 3°C
both	Calibration triggered by both time and temperature
tinnE	Calibration carried out in a specified time interval.

Calibration upon connection of the scale to the mains

- Upon completed start-up procedure, scale stability conditions regarding calibration are checked, the internal calibration is triggered automatically.
- Calibration process, when in progress, is signaled with display of 'dash', < - >.
- Upon completion, the scale automatically returns to the weighing mode.

Calibration upon temperature change

- The scale is equipped with precise system monitoring temperature variation and registering temperature value for each completed calibration process.
- Calibration process is triggered automatically at the moment when temperature measured by the scale changes by more than 3°C.
- Right before the adjustment process, scale stability conditions are checked.
- Calibration process, when in progress, is signaled with display of 'dash', < - >.
- Upon completion, the scale automatically returns to the weighing mode.

Calibration upon passage of specified time interval

- The scale is equipped with RTC, due to this time of each completed process is registered.
- Adjustment process is triggered automatically after passage of particular time interval, set in <1.6.CAC> parameter.
- Calibration process, when in progress, is signaled with display of 'dash', < - >.
- Upon completed calibration process, the scale automatically returns to the weighing mode.

12.5 Automatic Internal Calibration Time

Parameter determining time interval between successive automatic internal adjustments. The time interval is declared in hours and ranges between **0.5 [h]** and **12 [h]**.

Procedure:

- Enter <P1.CAL / 1.6.CAC> submenu.
- Press  key, available values, given in hours, are displayed successively one by one:

Available values: 05 H, 1 H, 2 H, 3 H, 4 H, 5 H, 6 H, 7 H, 8 H, 9 H, 10 H, 11 H, 12 H.

12.6 Calibration Test

Only available on models: PB-350-1000i, PB-350-2000i and PB-350-6000i

Calibration test function enables comparison of the internal adjustment results with the value recorded in factory parameters. Such comparison is used for determining drift of scale sensitivity over time.

Procedure:

- Enter <P1.CAL / 1.4.AtS> submenu, internal adjustment process starts automatically.
- Adjustment process, when in progress, is signaled with display of <CAL> text.
- Upon completed adjustment process, <1.4.CAtS> parameter is displayed automatically.



12.7 Calibration Report

Calibration report, and calibration test report are both automatically printed (using scale-connected printer) at the end of each calibration process. To declare report content go to **<P6.1.CrEP>** submenu. For detailed information concerning report content read later sections of this manual.

13 MAIN SCALE PARAMETERS

Scale parameters are set to adjust the weighing device to ambient conditions (filters) or individual needs (autozero on/off, tare values memory). These parameters are to be found in **<P2.rEAd>** submenu. **<P2.rEAd>** submenu comprises functions allowing you to adjust your weighing device to ambient conditions of given workstation.

13.1 Filter

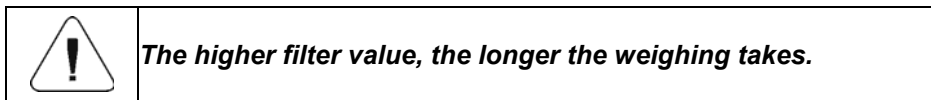

- Enter **<P2.rEAd / 2.1.FiL>** submenu.
- Press  key, filter values are displayed successively one by one: 1 - Fast, 2 - Average, 3 – Slow.
- Set respective value and press  key to confirm, next go to the home screen.



13.2 Value Release

Enter this parameter to adjust rate of stabilization of the measurement result. Depending on the selected option, weighing time is either shorter or longer.



Procedure:

- Enter **<P2.rEAd / 2.2.APPr>** submenu.
- Press  key, available values are displayed successively one by one: **F_P** - fast and reliable, **PrEc** – reliable, **FASt** – fast.
- Press  key to confirm, next go to the home screen.

13.3 Ambient Conditions

Parameter relating to ambient and environmental conditions of the workstation. Enter this parameter and set 'nStAb' value if the ambient conditions are unfavorable (air drafts, vibrations).

Procedure:



- Enter **<P2.rEAd / 2.3.Enut>** submenu.
- Press  key, parameter values are displayed successively one by one: **nStAb** – unstable, **StAb** – stable.
- Press  key to confirm, next go to the home screen.

13.4 Autozero Function

'Autozero' function has been designed to enable automatic control and correction of zero indication. This guarantees precise weighing results.

There are, however, some cases when this function can be a disturbing factor for the measuring process, e.g. very slow placing of a load on the weighing pan (load adding, e.g. pouring, filling). In such case, it is recommended to disable the function.

Procedure:

- Enter <P2.rEAd / 2.4.Aut> submenu.
- Press  key, parameter values are displayed successively one by one: **YES** – autozero function enabled, **no** – autozero function disabled.
- Press  key to confirm, next go to the home screen.

13.5 Tare Function

'Tare' function has been designed to enable setup of appropriate parameters for tare operation.



Procedure:

- Enter <P2.rEAd / 2.5.tArA> submenu.
- Press  key, available values are displayed successively one by one:

no	Regular tare mode. Select this parameter to make the scale overwrite the set (selected) tare value with the most recently entered one.
tArF	Select this parameter to make the scale store the latest tare value in memory. The latest tare value is displayed after scale restart.
AtAr	Automatic tare mode.
EAcH	Select this parameter to make the scale automatically tare each accepted measurement.





- Press  key to confirm, next go to the home screen.

13.6 Tare: Enter Mode

The tare is entered using  +  keys combination from the home screen level. There are two enter modes.

Procedure:

- Enter <P2.rEAd / 2.6.ttr> submenu.
- Press  key, parameter values are displayed successively one by one:





tArEH	Select to enter tare value manually by means of  +  keys combination.
tArnn	Select to enter tare value that is stored in scale memory, use  +  keys combination.



- Press  key to confirm, next go to the home screen.



13.7 Tare: Values Memory

It is possible to store 10 tare values in scale memory.



13.7.1. Entering Tare Value to the Weighing Device Memory

- Enter **<P2.rEAd / 2.7.tArn>** submenu, name of tare no. 1 from tares database is displayed (**<tArE 0>**), to select a different record press  key.
- Select respective entry and press  key, tare value edit box is displayed.
- Enter tare value, to do it press  and  keys:

	Press to select digit that is to be edited.
	Press to set digit value, 0 - 9 .

- Press  key to confirm, **<tArE 0>** window is displayed.
- Now press  key to go to the home screen.

13.7.2. Selecting Tare Value from the Weighing Device Memory

- Enter **<P2.rEAd / 2.7.tArn>** submenu, name of tare no. 1 from tares database is displayed (**<tArE 0>**), to select a different record press  key.
- To set the selected tare press  key.
- The set tare value is displayed with minus sign, **Net** symbol is shown in the upper-left corner of the screen:

	<i>The tare value acquired from the weighing device memory is not remembered upon the weighing device restart.</i>
---	---

13.8. Last Digit

Function designed to disable display of the last weighing indication digit, this results with less accurate measurement.

Procedure:

- Enter **<P2.rEAd / 2.8.LdiG>** submenu.



- Press key, available values are displayed successively one by one:

ALAS	Select to make the last digit always on.
nEur	Select to make the last digit always off.
uuSt	Select to make the last digit on only when the weighing indication is stable.

- Press  key to confirm, next go to the home screen.

14 COMMUNICATION

Communication between the scale and the peripheral devices is established via the following ports: RS232 (1), RS232 (2)*, USB Type A*, USB type B*. To set the ports go to **< P4.Conn >** submenu.

*These ports are not available on PB-350-30000P2.H or PB-350-60000P2.H

14.1 RS232 (1) Port

- Enter **<P4.Conn / 4.1.rS1>** submenu and set respective transmission parameters:

4.1.1.bAd	Baud rate: 2400, 4800, 9600, 19200, 38400, 57600, 115200
4.1.2.PAr	Parity: nonE – none; EuEn – even; Odd – odd.

- Press  key to confirm, next go to the home screen.

14.2 RS232 (2) Port

- Enter **<P4.Conn / 4.2.rS2>** submenu and set respective transmission parameters:

4.2.1.bAd	Baud rate: 2400, 4800, 9600, 19200, 38400, 57600, 115200 bit/s.
4.2.2.PAr	Parity: nonE – none; EuEn – even; Odd – odd.

- Press  key to confirm, next go to the home screen.

14.3 USB A Port

USB port of type A is intended for:

- Connecting a USB flash drive in order to enable
 - Operator's parameters export/import
 - Weighing reports export
 - Alibi report export

- Connecting scale to PRNT-01 Cole-Parmer Printer

14.4 USB B Port

USB port of type A is intended for connecting the scale to a computer. In order to make the connection of a scale and computer possible, it is necessary to install virtual COM port on the computer. For this software, please contact: support@schulerci.com

15 PERIPHERAL DEVICES



<P5.ducE> menu contains list of devices cooperating with scale.

15.1 Computer

<5.1.PC> submenu allows you to:

- select port to which the computer is connected,
- enable/disable continuous transmission,
- set frequency of printouts for continuous transmission.

15.1.1. Computer Port

- Enter <5.1.PC / 5.1.1.Prt> submenu.
- Press  key, parameter values are displayed successively one by one: **nonE** – none; **rS1** – RS232 (1); **rS2** – RS232 (2), **USbb** – USB type B
- Press  key to confirm, next go to the home screen.

15.1.2. Continuous Transmission

- Enter <5.1.PC / 5.1.2.Cnt> submenu.
- Press  key, parameter values are displayed successively one by one:

nonE	Continuous transmission disabled.
CntA	Continuous transmission in basic unit.
Cntb	Continuous transmission in current/temporary unit.

- Press  key to confirm, next go to the home screen.

15.1.3. Printout Interval for Continuous Transmission

Parameter enabling you to set frequency of printout for continuous transmission. Printout interval is set in seconds with 0.1 [s] accuracy within 0.1- 3600 [s] range.

Procedure:

- Enter <5.1.PC / 5.1.3.Int> submenu, window for entering interval value is displayed.
- Press  key to confirm, next go to the home screen.

15.2. Printer

15.2.1. Printer Port

Parameter enabling you to select port to which data is to be sent upon pressing  key.

Procedure:

- Enter <5.2.Prtr / 5.2.1.Prt> submenu.

- Press  key, parameter values are displayed successively one by one:

nonE	None port selected.
rS1	Port RS232 (1).
rS2	Port RS232 (2).
USbA	USB port of type A

- Press  key to confirm, next go to the home screen.

15.3. Additional Display

The weighing instrument can cooperate with additional WD displays.

15.3.1. Additional Display Port

- Enter <5.3.AdSP / 5.3.1.Prt> submenu.

- Press  key, parameter values are displayed successively one by one:
nonE – none; **rS1** – RS232 (1); **rS2** – RS232 (2).

- Press  key to confirm, next go to the home screen.

16 PRINTOUTS

It is possible to define adjustment report printout template and GLP printout template. To set the printouts go to < P6.Prt > submenu.

16.1 Calibration Report

<P6.1.CrEP> is a group of parameters allowing you to declare variables that are to be printed on an calibration report printout. Each variable features accessibility attribute: **YES** – print, **no** – do not print. Calibration report is automatically generated upon each completed calibration process.

Variables list:

No.	Name	Description
6.1.1.	CtP	Performed calibration type.
6.1.2.	dAt	Calibration Date
6.1.3.	tin	Calibration time.
6.1.4.	ldb	Serial number of the scale.

6.1.5.	CdF	Difference between mass of Calibration weight that was measured during last Calibration and mass of currently measured Calibration weight.
6.1.6.	dSh	Dashed line separating printout data and signature fields.
6.1.7	SiG	An area for the signature of the operator carrying out the calibration

	<i>Printouts are generated exclusively in English.</i>
---	---

Report example:

```

-----Calibration Report-----
Calibration type           External
Date                       2016.10.15
Time                       12:39:23
Balance ID                 123456
Difference                  -0.02g
-----
Signature
.....

```

16.2 GLP Printout

<P6.2.GLP> is a group of parameters allowing you to declare variables that are to be printed on a weighing printout. Each variable features accessibility attribute: **YES** – print, **no** – do not print.

16.3 Variables List

No.	Name	Description
6.2.1.	dAt	Performed weighing date.
6.2.2.	tin	Performed weighing time.
6.2.3.	ldb	Serial number of the scale.
6.2.4.	n	Net weight value of performed weighing in basic measuring unit.
6.2.5.	t	Tare weight value in the current unit.
6.2.6.	b	Gross weight value in the current unit.
6.2.7.	CrS	Current weighing result (net weight) in a current unit.
6.2.8.	CrP	The last adjustment report generated in accordance with settings declared for the adjustment report printout.

	<i>Printouts are generated exclusively in English.</i>
---	---

Report example:

```

Date           2016.10.15
Time           12:04:17
Net            49.98g
Tare           17.20g
Gross          67.18g

```

17 OTHER PARAMETERS

<P7.Othr> is a group of parameters enabling you to adapt the scale to individual needs.

17.1 Backlight

Parameter allowing you to change display brightness, the brightness can be changed within **0%** - **100%** range.

Procedure:

- Enter <P7.Othr / 7.1.bLbt> submenu.
- Press  key, parameter values are displayed successively one by one, where:



nonE	Backlight off.
10	Display brightness low limit value in [%].
100	Display brightness high limit value in [%].

- Press  key to confirm, next go to the home screen.

17.2 'Beep' Sound

Parameter allowing you to enable/disable sound signal informing the operator about pressing panel key(s).

Procedure:



- Enter <P7.Othr / 7.2.bEEP> submenu.
- Press  key, parameter values are displayed successively one by one: **no** – sound signal disabled, **YES** - sound signal enabled.
- Press  key to confirm, next go to the home screen.

17.3 Automatic Shutdown

Parameter allowing you to set time interval, in [min], after which the weighing device shuts down automatically. If the indication is stable during the declared time interval, the device is shut down automatically.

Shutdown function is inactive and the device cannot be turned off if any process is started or if you operate the menu.

Procedure:

- Enter <P7.Othr / 7.3.t1> submenu.
- Press  key, parameter values are displayed successively one by one: **nonE** – function disabled, **1, 2, 3, 5, 10**.
- Press  key to confirm, next go to the home screen.

17.4 Date and Time

Parameter allowing you to set current date and time and to specify date and time format.

Procedure:

- Enter **<P7.Othr>** submenu and change the settings. Refer to the below table:

Parameter	Description
<7.4.SdAt>	Enter this parameter to set current date, where the date format is YYYY.MM.DD* .
<7.5.Stnn>	Enter this parameter to set current time, where the time format is 24H** .
<7.6.FdAt>	Enter this parameter to select date format. Available values: 1 - DD.MM.YYYY, 2 - MM.DD.YYYY, 3 - YYYY.MM.DD* (set by default), 4 - YYYY.DD.MM.
<7.7.Ftin>	Enter this parameter to select time format. Available values: 24H** (set by default), 12H** .

*) - Date format: Y – year, M – month, D – day.

***) - Time format: 12H – 12-hour format, 24H - 24-hour format.

17.5 Default User Settings

Parameter allowing you to restore default operator settings.

Procedure:

- Enter **<P7.Othr / 7.8.dFLu>** submenu, text **<Cont?>** is displayed (Continue?).



- Press **ENTER** key to confirm. The process of restoring default settings starts, this is signaled with display of 'dash', **< - >**.
- Upon process completion **<7.8.dFLu>** submenu is displayed. Go to home screen.

18 SCALE DATA

Scale data menu, **<P8.InFo>**, provides information on the weighing device and its program. The parameters serve informative purposes:



Parameter	Description
<8.1.Idb>	Serial number of the scale.
<8.2.PurS>	Program version.
<8.3.PStP>	Settings printout. Enter the parameter to send scale settings to printer port (all parameters).

19 WORKING MODES

The weighing device features the following working modes:

- Weighing
- Parts counting
- +/- control
- Percent weighing %
- Peak Hold
- Totalizing
- Animal weighing

19.1 Running Working Mode

- Go to home screen, press  key, name of the first available working mode is displayed.
- Press  key, names of available working modes are displayed successively one by one.
- Enter selected working mode, to do it press  key.

 **The weighing device program has been designed to make the scale run, upon restart, with the latest operated working mode on.**

19.2 Working Modes Local Settings

Each working mode features specific (local) functions which enable adapting device operation to individual needs. The functions are to be found in local settings. To go to local settings of each working mode enter **<P3.Func>** submenu. Some special functions are available for all working modes, refer to the table below:



	Accessibility	Save mode	Time	Lo threshold
Weighing	3.1.1.Acc	3.1.2.Snn	3.1.3.Int	3.1.4.Lo
Parts counting	3.2.1.Acc	3.2.3.Snn	3.2.4.Int	3.2.5.Lo
+/- control	3.3.1.Acc	3.3.2.Snn	3.3.3.Int	3.3.4.Lo
Percent weighing %	3.4.1.Acc	3.4.3.Snn	3.4.4.Int	3.4.5.Lo
Peak Hold	3.5.1.Acc	-	-	3.5.2.Lo
Totalizing	3.6.1.Acc	3.6.2.Snn	3.6.3.Int	3.6.4.Lo
Animal weighing	3.7.1.Acc	-	-	3.7.3.Lo

The table presents special function number and name for each of the working modes. Remaining specific functions referring directly to a given working mode are described further down this user manual.

19.2.1. Working Mode Accessibility

To enable/disable given working mode, press  key.

Procedure:

- Enter **<P3.Func>** menu and select given working mode.
- Go to **<Acc>** function.
- Press  key, parameter values are displayed successively one by one: **YES** – working mode enabled, **no** – working mode disabled.
- Press  key to confirm, next go to the home screen.



19.2.2. Save Mode

Parameter allowing you to set mode of sending data from the weighing device to a peripheral device.

Procedure:

- Enter **<P3.Func>** menu and select given working mode.
- Go to **<Snn>** function.

- Press  key, parameter values are displayed successively one by one:

StAb	Manual printout of stable  weighing result. Upon pressing  key at the moment when the result is unstable (no pictogram displayed), the program first waits for the stability condition to be met, only then printout is carried out.
nStAb	Manual printout of each weighing result. In case of unstable indication, <?> sign is displayed in front of the 'mass frame'.
rEPL	Automatic printout of the first stable weighing result above <Lo> threshold (to set <Lo> threshold go to <Lo> parameter).
rEPLi	Automatic printout with time interval set in [min] (to set the interval go to <Int> parameter).

- Press  key to confirm, next go to the home screen.

19.2.3. Automatic Printout Time Interval

Parameter enabling you to set frequency of automatic printout. Printout interval is set in minutes with 1 [min] accuracy within 1 [min] - 1440 [min] range.

Procedure:

- Enter **<P3.Func>** menu and select given working mode.
- Enter **<Int>** function, window for entering **time interval** value is displayed.

- Press  key to confirm, next go to the home screen.

19.2.4. Lo Threshold

<Lo> parameter allows you to configure the function of automatic operation. In order to save the next measurement, before carrying it out the mass indication must get below the set net value of Lo threshold.

Procedure:

- Enter **<P3.Func>** menu and select given working mode.
- Enter **<Lo>** function, window for entering **Lo threshold** value is displayed.

- Enter respective value and press  key to confirm, then continue weighing.

20 WORKING MODE – WEIGHING

<UUGG> is a standard working mode enabling you to carry out the weighing operation along with record of the result to the database.

20.1 Local Settings

To go to local settings enter <3.1.UUGG> submenu.

3.1.1.Acc	Working mode accessibility
3.1.2.Snn	Save mode
3.1.3.Int	Time interval
3.1.4.Lo	Lo threshold

21 WORKING MODE – PARTS COUNTING

Parts Counting is a working mode enabling you to determine quantity of small pieces of the same mass, which determination is done on the basis of mass of sample piece (single part), and where the sample piece mass (single part mass) is determined using the weighing device.

21.1 Local Settings

To go to local settings enter <3.2.PcS> submenu.

3.2.1.Acc	Working mode accessibility
3.2.2.UUt	Operation mode
3.2.3.Snn	Save mode
3.2.4.Int	Time interval
3.2.5.Lo	Lo threshold

21.1.1. Selecting Working Mode

Parameter allowing you to select method of determination of sample piece mass.

Procedure:

- Enter <3.2.PcS / 3.2.2.UUt> submenu.
- Press  key, parameter values are displayed successively one by one:

S_S	Select to set sample mass by determining mass of a single part.
Suu	Select to set sample mass by entering mass of a single part.

- Enter respective value and press  key to confirm, then continue weighing.

21.2. Setting Sample Mass by Entering Mass of a Single Part

- Enter <3.2.PcS / 3.2.2.UUt> submenu, set <Suu> value.
- Enter <PcS> working mode (parts counting), first, text <SEt_Ut> is displayed for 1 s, next, window for entering mass value of a single part.

- Enter respective value and press  key to confirm, home screen is displayed automatically along with quantity of parts loaded onto the weighing pan (pcs).



	<i>If the value of entered single part mass is greater than max capacity value, then message <Err Hi> is displayed.</i>
---	--





21.3. Setting Sample Mass by Determining Mass of a Single Part

- Enter <3.2.PcS / 3.2.2.UUt> submenu, set <S_S> value.
- Enter <PcS> working mode (parts counting), blinking value of sample quantity is displayed.

- Press  key to select one of the following options:

10	Reference sample quantity: 10 pcs.
20	Reference sample quantity: 20 pcs.
50	Reference sample quantity: 50 pcs.
100	Reference sample quantity: 100 pcs.
0000	Custom reference sample quantity - enter the required value yourself.

- Select respective option and press  key to confirm, first, text <LoAd> is displayed for 1 second, then the weighing window.
- If the parts are to be weighed in a container, first put the container on a weighing pan and tare it.
- Load the weighing pan with declared amount of parts. When the indication is stable ( pictogram is displayed), press  key to confirm the mass.
- Single part mass is calculated automatically, next quantity of parts (pcs) is displayed.

	<i>Total weight value of all parts loaded onto the weighing pan cannot be greater than the max capacity value.</i>
	<i>Single part mass value must be equal or greater than 0.1 of the reading unit. Unless this condition is met, the weighing device displays a message <ErrLo>.</i>
	<i>In the course of parts quantity determination before confirming the declared quantity value it is necessary to wait for a stable  measurement .</i>

22 WORKING MODE – +/- CONTROL

+/- control is a working mode enabling you to enter checkweighing thresholds values (**Min**, **Max**).

22.1 Local Settings

To go to local settings enter <3.3.HiLo> submenu.

3.3.1.Acc	Working mode accessibility
3.3.2.Snn	Save mode
3.3.3.Int	Time interval
3.3.4.Lo	Lo threshold



22.2 Declaring Checkweighing Thresholds

- Enter <HiLo> working mode (+/- control), first, text <SEt Lo> is displayed for 1 s, next, window for declaring low weighing threshold (Min).

- Enter respective value and press  key to confirm, first, text <SEt Hi> is displayed for 1 second, next, window for declaring high weighing threshold (Max).

- Enter respective value and press  key for confirmation, working mode's home screen is displayed along with declared threshold value, where:

Min	Load mass lower than low weighing threshold.
Ok	Load mass within weighing thresholds.
Max	Load mass greater than high weighing threshold.

	<i>If the entered low threshold value (Min) is greater than high threshold value (Max), <Err Lo> error is displayed.</i>
	<i>If the entered high threshold value (Max) is greater than the maximum capacity value, <Err Hi> error is displayed.</i>

23 WORKING MODE – PERCENT WEIGHING

Percent weighing is a working mode enabling you to compare measured load mass with the reference sample mass. The result is expressed in [%]. Reference sample mass can be either determined by weighing or entered to weighing device memory by an operator.

23.1 Local Settings

To go to local settings enter <3.4.dEu> submenu.

3.4.1.Acc	Working mode accessibility
3.4.2.UUt	Operation mode
3.4.3.Snn	Save mode
3.4.4.Int	Time interval
3.4.5.Lo	Lo threshold

23.1.1. Selecting Working Mode

Parameter allowing you to select method of determination of reference sample mass.



Procedure:

- Enter <3.4.dEu / 3.4.2.UUt> submenu.
- Press  key, parameter values are displayed successively one by one:

S_S	Select to set reference sample mass by determining the mass value.
Suu	Select to set reference sample mass by entering the mass value.

- Set respective value and press  key to confirm, next go to the home screen.

23.2. Reference Sample Mass Determined by Weighing

- Enter <3.4.dEu / 3.4.2.UUt> submenu, set <S_S> value.
- Enter <dEu> working mode (Percent weighing), first, text <LoAd> is displayed for 1 second, then the weighing window.
- Load the weighing pan with the reference sample. When the indication is stable ( pictogram is displayed), press  key to confirm the mass.
- Mass of the weighed load is automatically set as reference sample mass; the home screen is displayed along with **100.000%** value.

23.3. Reference Sample Mass Determined by Entering the Mass Value

- Enter <3.4.dEu / 3.4.2.UUt> submenu, set <Suu> value.
- Enter <dEu> working mode (Percent weighing).
- Text <SEt_Ut> is displayed for 1 s, next, window for declaring mass of reference sample.
- Enter respective value and press  key to confirm. The home screen is displayed automatically with **0.000%** value.

	<i>If the value of entered reference sample mass is greater than max capacity value, then message <Err Hi> is displayed.</i>
---	--

24 WORKING MODE – PEAK HOLD

Peak Hold is a working mode allowing you to snap value of maximum force applied to the weighing pan during one weighing process.

24.1 Local Settings

To go to local settings enter <3.5.toP> submenu.

3.5.1.Acc	Working mode accessibility
3.5.2.Lo	Lo threshold

24.2 Peak Hold Operation

- Enter **<3.5.toP / 3.5.2.Lo>** submenu, set **<Lo>** parameter value (Lo threshold) after exceeding of which maximum force is to be registered.
- Enter **<toP>** working mode (Peak Hold). From now on the scale registers and holds every single weighing which is above the **Lo threshold**, and which is higher than the result of the previous peak hold. Snapped peak hold value is signaled by **<Max>** pictogram displayed at the top of the screen.
- The start of the next process of peak hold measurement is possible only after removing the load from the

weighing pan and pressing  key.

- This causes returning to the home screen of **<toP>** mode. Pictogram **<Max>** is automatically deleted.

25 WORKING MODE – TOTALIZING

Totalizing is a working mode enabling you to sum mass of all weighed ingredients, and to print (via scale-connected printer) the total mass value. The program allows you to sum up to 30 weighings (ingredients) maximum within one process.

25.1 Local Settings

To go to local settings enter **<3.6.Add>** submenu.

3.6.1.Acc	Working mode accessibility
3.6.2.Snn	Save mode
3.6.3.Int	Time interval
3.6.4.Lo	Lo threshold

25.2 Totalizing Operation

- Enter **<Add>** working mode (Totalizing) blinking „▲” pictogram is displayed.
- If the ingredients are to be weighed in a container, first put the container on a weighing pan and tare it.
- Load the weighing pan with the ingredient no.1. When the indication is stable (▲ pictogram is displayed),

press  key to confirm the mass.

- Total mass value is displayed, now the “▲” pictogram is displayed continuously.
- Unload the weighing pan, **ZERO** is displayed, “▲” marker starts blinking again.

- Load the weighing pan with the ingredient no.2, wait for a stable weighing result and press  key.
- Total mass value of ingredient no. 1 and 2 is displayed, now the “▲” pictogram is displayed continuously.

- In order to finish the process, press  key, text **<Prnt?>** (Print?) is displayed.

- Press  key, total mass value of all recorded weights are printed on a scale-connected printer.

25.3 Report Example

(1)	13.500 g
(2)	14.400 g
(3)	9.700 g
(4)	100.500 g
(5)	4.000 g
(6)	8.200 g
(7)	20.800 g
(8)	5.800 g

Total:	176.900 g

- In order to print the report once again press  key.

- To exit "report printout mode" press  key. As a result home screen of **<Add>** working mode is displayed and all the data get zeroed automatically.

	<i>If the display capacity is exceeded (i.e. there is not enough space for all the digits of the weighing result) <Hi> error is displayed. In such a case either remove the ingredient from a weighing pan and finish the totalizing process or place load of a lower weight value on the weighing pan.</i>
---	---

26 WORKING MODE – ANIMAL WEIGHING



Animal Weighing is a working mode enabling you to weigh products that disrupt efficient establishing of stability. It is mostly intended to measure weight of animals.

26.1 Local Settings

To go to local settings enter **<3.7.AnLS>** submenu.

3.7.1.Acc	Working mode accessibility	
3.7.2.Aut	Averaging time	Enter this parameter to declare duration of the process in seconds (5s, 10s, 20s, 30s, 40s, 50s, 60s) - on the basis of indications recorded within the set time interval the scale calculates the weighing result, i.e. an average weight value.
3.7.3.Lo	Lo threshold	

26.2 Animal Weighing Operation

- Enter **<AnLS>** working mode (Animal Weighing).
- First text **<tinnE>** is displayed for 1 s, next, window for setting duration (in seconds) of animal weighing.
- Press  key, parameter values are displayed successively one by one: 5[s], 10[s], 20[s], 30[s], 40[s], 50[s], 60[s].
- Set the respective value, press  key to confirm, weighing window with **A** letter is displayed.
- Load the weighing pan with an animal.
- On exceeding the set mass value of **<Lo> threshold** parameter, animal weighing starts, this is signaled

with display of 'dash', < -

>.

- Upon process completion mass value of an animal is snapped and displayed together with **OK** pictogram in the upper part of the display. The snapped mass value is sent to a scale-connected printer.



- Press  key to restart animal weighing.



- Press  key to reprint the snapped mass value.
- Upon unloading of the weighing platform, the weighing window with letter **A** is displayed. The scale can be loaded with an animal again.

27 IMPORT/EXPORT

Function enabling you to archive weighing reports and Alibi reports and to copy parameters between weighing devices of the same series. Import/export operation can be carried out by means of USB flash drive comprising **<FAT files system>**. Upon connection of the USB flash drive to the USB A port, the drive gets detected automatically as a result **<IE>** sub menu is created. Since extensions of exported weighing reports and Alibi reports files are specific and the file-stored data is encoded it requires a special software. For this software, please reach out to support@schulerci.com .

27.1 Weighing Records Export

Option enabling you to export weighing to a USB flash drive. Weighing device program offers option of record of 5000 weighings

Procedure

- Connect the USB flash drive to USB A port
- Enter **<IE / IE1.UUE>** Submenu
- The program automatically saves exported data to a USB flash drive file
 - File name and extension: xxxxxx.wei, where xxxxxx – serial number

27.2 ALIBI Weighings Export

Option enabling you to export ALIBI weighing to a USB flash drive. Weighing device program offers option of record of 100000 weighings

Procedure

- Connect the USB flash drive to USB A port
- Enter **<IE / IE2.ALE>** Submenu
- The program automatically saves exported data to a USB flash drive file
 - File name and extension: xxxxxx.ali, where xxxxxx – serial number

27.3 Parameters Export / Import

Export / import of all user parameters between weighing devices of the same series carried out using USB flash drive.

Procedure

- Connect the USB flash drive to USB A port
- Enter **<IE / IE3.SPE>** Submenu
- The program automatically saves exported data to a USB flash drive file
 - File name and extension: xxxxxx.par, where xxxxxx – serial number

Import procedure

- Connect the USB flash drive to USB A port, make sure that the drive stores parameters file in the main

- directory (file name: xxxxxx.par, where xxxxxx – serial number)
- Enter <IE / IE4.SPI> Submenu
- User parameters are automatically imported from xxxxxx.par file

28 DIAGRAMS OF CONNECTION CABLES

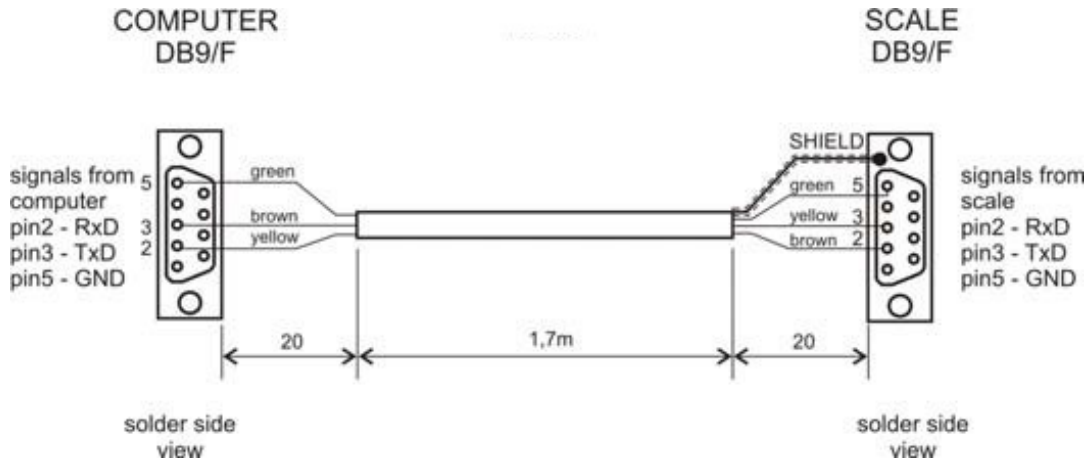

scale – computer cable

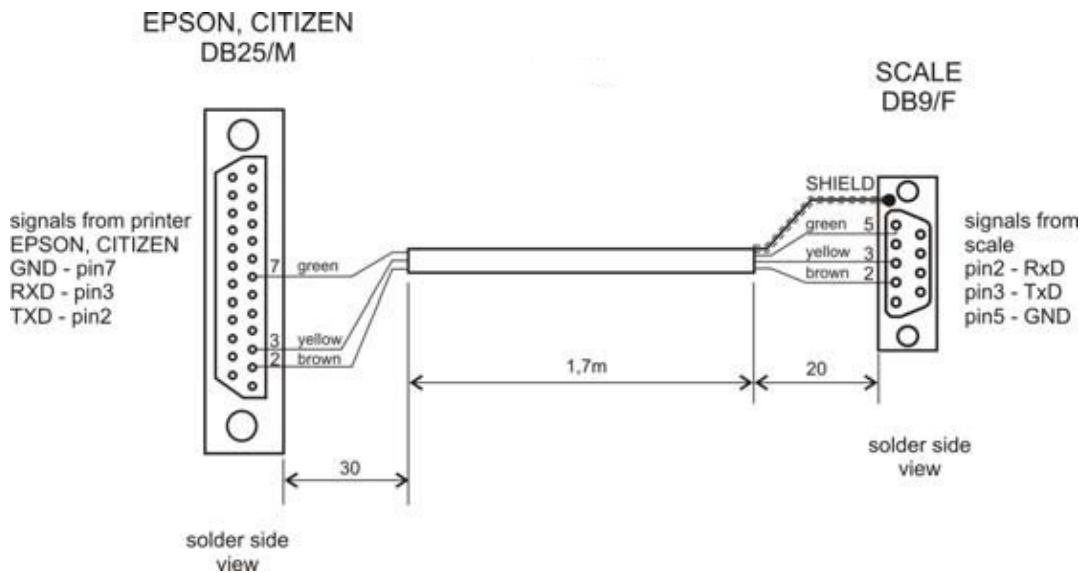

scale - printer cable (10100-84)

29 ERROR COMMANDS

- E r 2 -	Value beyond zero range.
- E r 3 -	Value beyond tare range.
- E r 4 -	Adjustment weight or start mass out of range ($\pm 1\%$ for adjustment weight, ± 10 for start mass).
- E r 5 -	Battery error. Battery is damaged.
- E r 8 -	Time of the following operations exceeded: taring, zeroing, start mass determining, adjustment process.
-Err9-	Time for internal weight lifting/dropping down exceeded
- n u l -	Zero value from converter.
- F U L -	Weighing range exceeded.
- L H -	Start mass error, indication out of range ($\square 10\%$ of start mass).
- H i -	Display range of total mass on scale display exceeded in 'Totalizing' mode.
- u L o -	Too low battery charge. The scale is about to shut down.
- E r L o -	<ul style="list-style-type: none"> - Determined mass of single part in 'Parts counting' mode too small. - Value of 'Min' threshold is greater than value of 'Max' threshold in '+/- control' mode.
- E r H i -	<ul style="list-style-type: none"> - Entered value of single part greater than maximum capacity in 'Parts counting' working mode. - Entered value of 'Max' threshold greater than maximum capacity in '+/- control' mode. - Entered reference mass greater than maximum capacity in 'Percent weighing' mode.

Notice:

1. Errors: **Err2, Err3, Err4, Err5, Err8, Err9, null**, that appear on the display are also signaled by a short beep sound (about 1 sec.);
2. Error **FULL2** that appears on the display is also signaled by a continuous sound until the cause of error disappears.

30 UNDER-PAN WEIGHING

The scale offers under-pan weighing option wherein the load is weighed when hanged under the device. This is especially useful when there is a need to weigh a load of non-standard dimension, shape, or load that generates an electromagnetic field.

Preparing the scale for under-pan weighing:

1. Unpack the scale, assemble it, then turn the scale one side down.

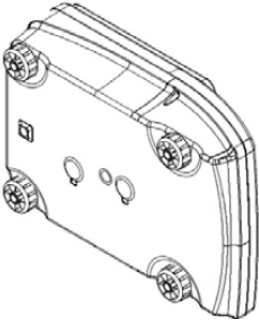

2. Remove the hole plug.

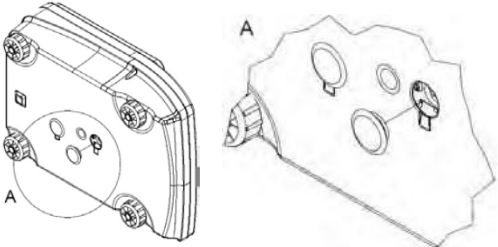

3. Fix the hook.

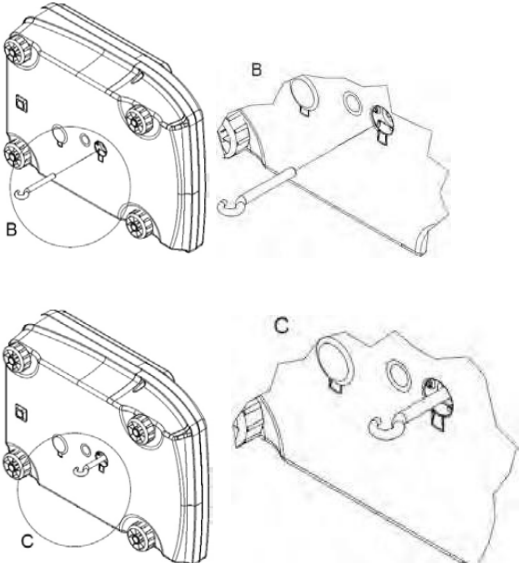

4. Turn the scale bottom side down.

31 MAIN DIMENSIONS

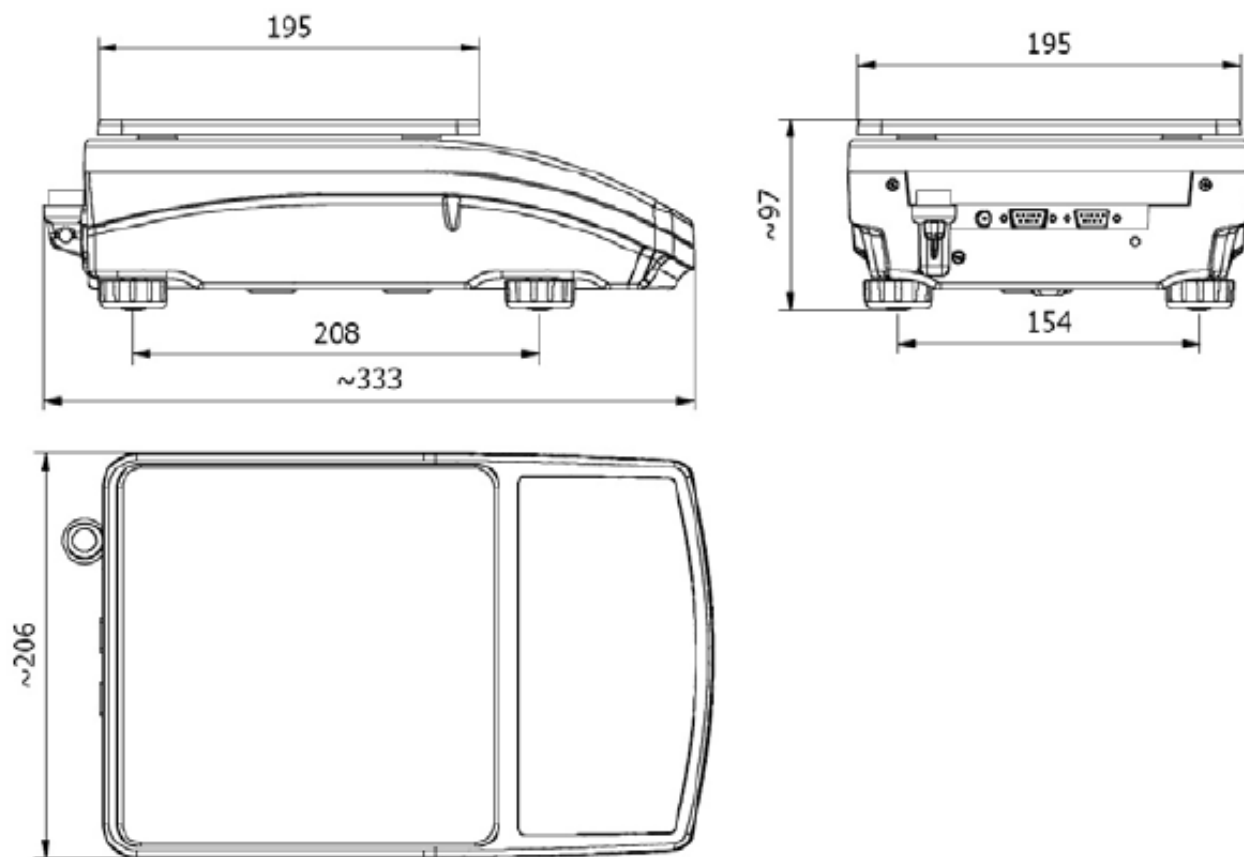

32 TROUBLE SHOOTING

Problem	Cause	Solution
Scale start-up fail.	Power supply disconnected.	Connect the power supply to the scale.
	Battery discharged.	Connect the power supply to the mains, charge the battery.
	No battery (not installed or installed incorrectly).	Check if the battery is installed correctly (polarization).
The scale switches off automatically.	<7.4.t1> parameter set to value enforcing scale shut-down after particular time interval.	Go to <P7.Othr> menu, set <7.4.t1> parameter to 'nonE' value.
During the start-up, message 'LH' is displayed.	Weighing pan loaded during the start-up.	Unload the weighing pan. Zero indication is displayed.
Communication with the computer not established.	Incorrect computer port set in parameter <5.1.1.Prt>.	Enter < P5.ducE / 5.1.PC> submenu and set correct <5.1.1.Prt> parameter value.
	Incorrect transmission parameters for the selected computer port.	Enter <P4.Conn> menu and set correct transmission parameters for the selected computer port.
	Incorrect printout frequency settings for continuous transmission.	Enter < P5.ducE / 5.1.PC> submenu and set correct <5.1.3.Int> parameter value.
No printout on a scale-connected printer.	Incorrect printer port set in <5.2.1.Prt> parameter.	Enter < P5.ducE / 5.2.Prtr> submenu and set correct <5.2.1.Prt> parameter value.
	Incorrect transmission parameters for the selected printer port.	Enter <P4.Conn> menu and set correct transmission parameters for the selected printer port.
	No variable declared in weighing printout project.	Enter <P6.Prt / 6.2.GLP> submenu and declare variables that are to be printed.
Communication with the additional display not established.	Incorrect additional display port set in <5.3.1.Prt> parameter.	Enter < P5.ducE / 5.3.AdSP> submenu and set correct <5.3.1.Prt> parameter value.
	Incorrect transmission parameters for the selected computer port.	Enter <P4.Conn> menu and set correct transmission parameters for the selected additional display port.
Displayed mass unit does not comply with the scale data plate.	Changed scale start unit in <9.1.UnSt> parameter.	Enter <P9.Unit / 9.1.UnSt> submenu and set unit complying with the scale data plate.
	Changed custom unit in <9.2.Unin> parameter.	Enter <P9.Unit / 9.2.Unin> submenu and set unit complying with the scale data plate.

It is recommended that Cole-Parmer products are calibrated annually to ensure proper function and accurate measurements; however, your quality system or regulatory body may require more frequent calibrations. To schedule your recalibration, please contact InnoCal, an ISO 17025 calibration laboratory accredited by A2LA.

INNOCAL®

INNOVATIVE CALIBRATION SOLUTIONS

Phone: 1-866-INNOCAL (1-866-466-6225)

Fax: 1-847-327-2993

E-mail: sales@innocalsolutions.com

Web: InnoCalSolutions.com

For Product and Ordering Information, Contact:

 **Cole-Parmer®**

Toll-Free: 1-800-323-4340

Phone: 1-847-549-7600

Fax: 1-847-247-2929